

Please check the examination details below before entering your candidate information

Candidate surname

Other names

**Pearson Edexcel  
Functional Skills**

Centre Number

Candidate Number

**Sample assessment material for first teaching  
September 2019**

Time: 1 hour 30 minutes

Paper Reference **SAML2/01**

**Mathematics**

**Level 2**

**Section B (Calculator)**



**You must have:**

Pen, calculator, HB pencil, eraser, ruler graduated in cm and mm, protractor, pair of compasses.

Total Marks

**My signature confirms that I will not discuss the content of the test with anyone.**

Signature: \_\_\_\_\_

### Instructions

- Use a **black** ink or ball-point pen.
- **Fill in the boxes** at the top of this page with your name, centre number and candidate number.
- Sign the declaration.
- Answer **all** questions.
- Write your final answers in the boxes provided.
- Answer the questions in the spaces provided – *there may be more space than you need.*
- You **must** show clearly how you get your answers in the spaces provided. Marks will be awarded for your working out.
- Check your working and your answers at each stage.
- Diagrams are **not** accurately drawn, unless otherwise indicated.
- If your calculator does not have a  $\pi$  button take the value of  $\pi$  to be 3.14
- **Calculators may be used.**

### Information

- The total mark for this section is 48
- The total mark for this paper is 64
- The marks for each question are shown in brackets.  
– *use this as a guide to how much time to spend on each question.*
- This sign  shows where marks will be awarded for showing your checks.

### Advice

- Read each question carefully before you start to answer it.
- Check your answers if you have time at the end.

Turn over ►

S64853A

©2019 Pearson Education Ltd.

1/1/1



Pearson

## SECTION B

Answer ALL questions. Write your answers in the spaces provided.

- 1 Data set A has a median value of 3.1

Here is data set B.

14    -9    28    -38    -13    -2

- (a) Write a statement to compare the median values of the two sets of data.

(2)



- (b) Show a check of your answer for the median of data set B.

(1)

**(Total for Question 1 is 3 marks)**

DO NOT WRITE IN THIS AREA

DO NOT WRITE IN THIS AREA

DO NOT WRITE IN THIS AREA

2 Dan throws two fair dice.

The numbers on dice A are            1   -2   3   -4   5   -6

The numbers on dice B are           -1   2   -3   4   -5   6

The table shows some total scores from throwing the two dice.

		Dice A						
		+	1	-2	3	-4	5	-6
Dice B	-1		0	-3	2	-5		-7
	2		3		5	-2	7	
	-3		-2	-5		-7		
	4		5	2		0		
	-5		-4		-2		0	-11
	6				9	2		0

(a) Complete the table.

(1)

Dan throws the two dice once.

(b) What is the probability that the total score is -11?

(1)

Dan throws the two dice again.

(c) What is the probability that the new total score is 0?

(1)

**(Total for Question 2 is 3 marks)**

3 Last year Zack had two jobs.

Zack worked

- in an office for 12 months and earned £2600 per month
- at a gym for 39 weekends and earned £80 per weekend.

What fraction of his total income last year came from his work at the gym?  
Write the fraction in its simplest form.

(4)

$$\frac{\square}{\square}$$

**(Total for Question 3 is 4 marks)**

DO NOT WRITE IN THIS AREA

DO NOT WRITE IN THIS AREA

DO NOT WRITE IN THIS AREA

- 4 Here is a prism.  
The cross section of the prism is a pentagon.

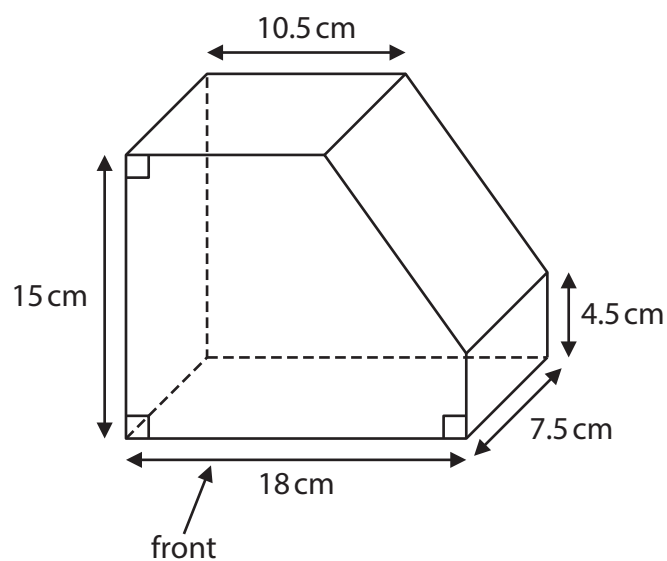

Draw the front elevation of the prism on the grid.  
Use the scale 1 : 3

(3)

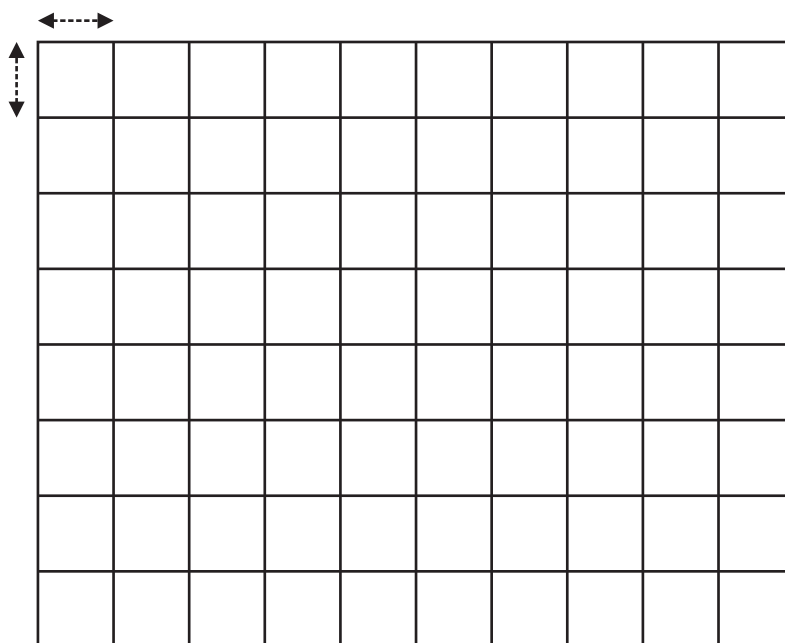

**Key**

←-----→ 1 cm on the page

(Total for Question 4 is 3 marks)

5 Olga has this sketch of the paths in a park.

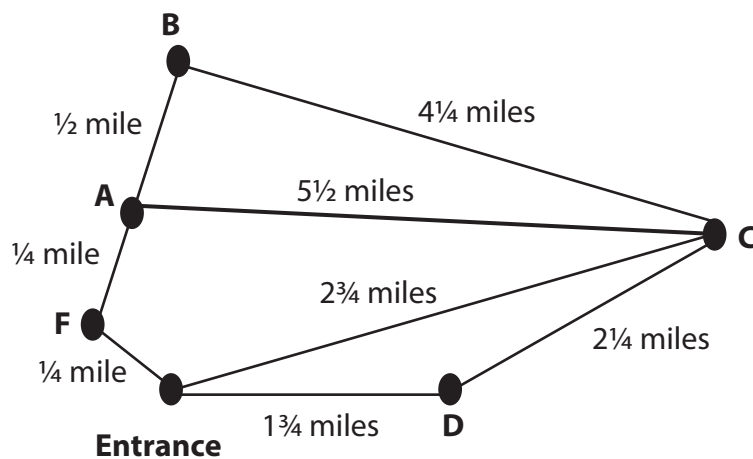

She wants a cycle route that

- starts and ends at the entrance
- goes through point C at least once
- has a total length between 15 **kilometres** and 20 **kilometres**.

1 km = 0.6 miles.

Plan a suitable route.

Work out the total distance of the route.

(5)

DO NOT WRITE IN THIS AREA

DO NOT WRITE IN THIS AREA

DO NOT WRITE IN THIS AREA

Route

Total distance

**(Total for Question 5 is 5 marks)**

6 Here is a cube of side length 2.5 cm.

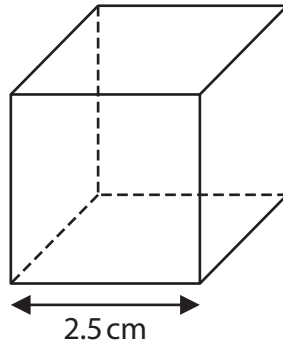

Work out the surface area of this cube.

(3)

cm<sup>2</sup>

**(Total for Question 6 is 3 marks)**

DO NOT WRITE IN THIS AREA

DO NOT WRITE IN THIS AREA

DO NOT WRITE IN THIS AREA

- 7 Megan is the manager of a computer shop.  
She organises a sale with 18% off all tablets.

Megan changes the price of one tablet from £389 to £330.98

(a) Has Megan changed the price correctly?

(3)



(b) Use estimation to show a check of your answer.

(1)

**(Total for Question 7 is 4 marks)**

8 A team of workers deliver identical fridges.

The team will use the average time to fully load an old lorry to predict the time to fully load a new lorry.

The table shows the times it took to fully load the old lorry with 24 fridges.

Time (mins)	52	60	55	59	54	63	56
-------------	----	----	----	----	----	----	----

The diagram shows the space available for fridges in the new lorry. The space is in the shape of a cuboid.

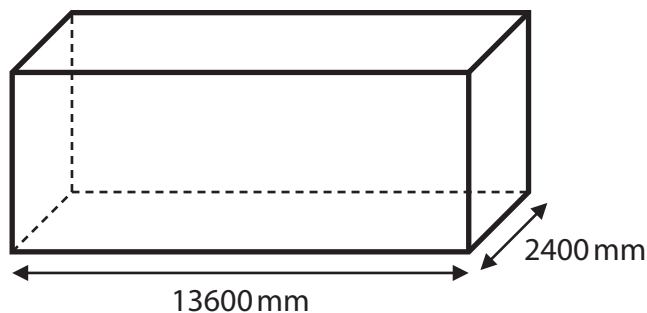

Each fridge needs a rectangular floor space 1000 mm by 800 mm.

The team do not stack fridges.

They think it will take less than 90 minutes to fully load the new lorry.

Are they correct?

(6)

DO NOT WRITE IN THIS AREA

DO NOT WRITE IN THIS AREA

DO NOT WRITE IN THIS AREA

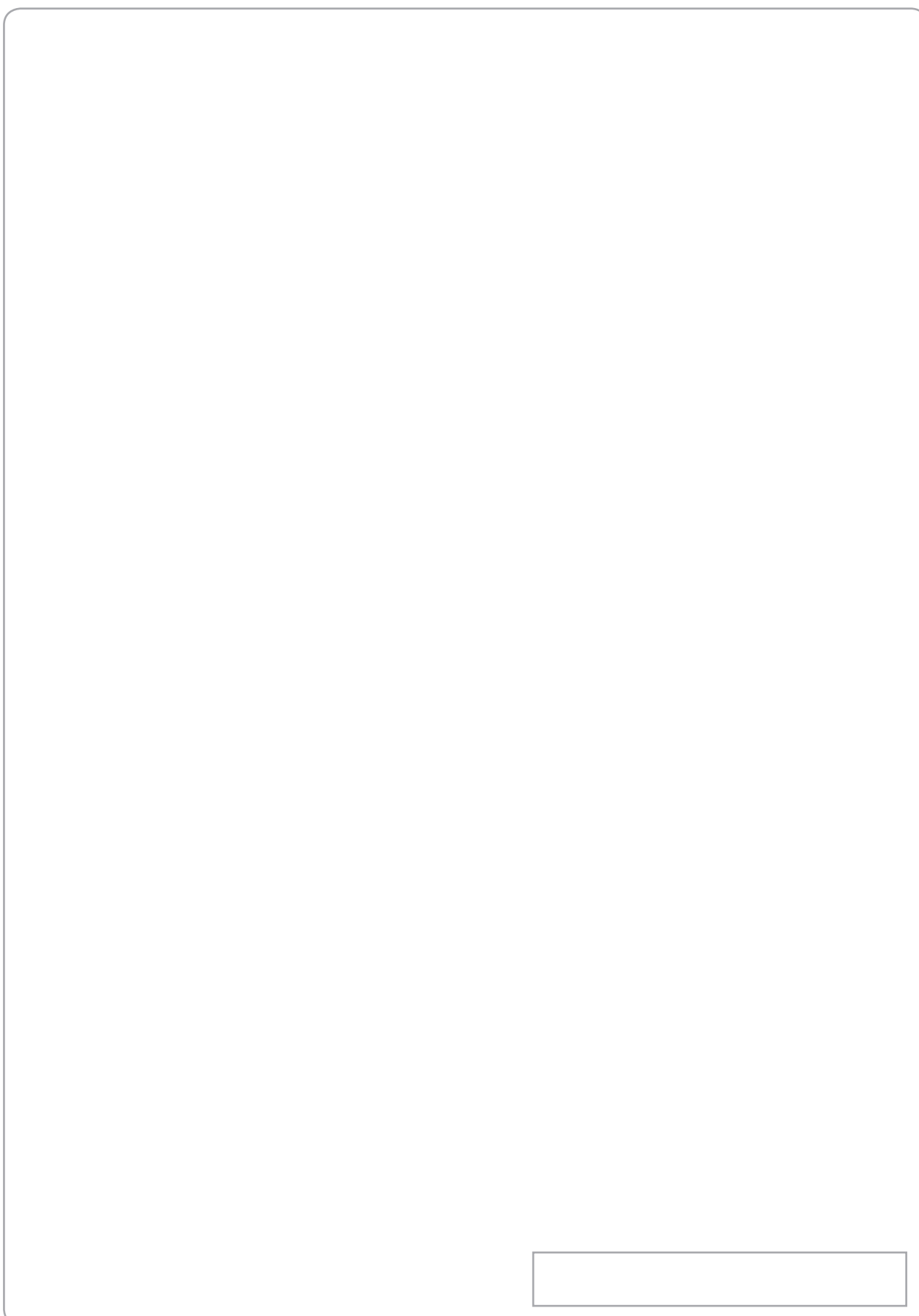

**(Total for Question 8 is 6 marks)**

- 9 Louis makes a cake.  
The cake is in the shape of a cylinder with diameter 14 inches.

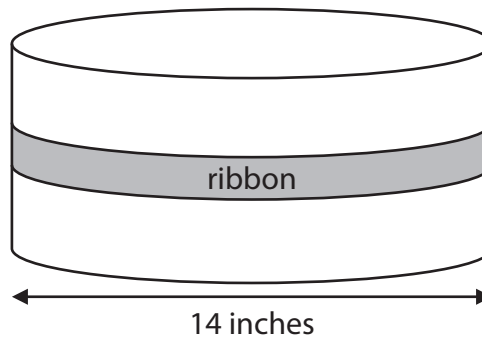

Louis needs to put a ribbon around this cake.  
The ribbon will go around the cake once with a 6 inch overlap.  
Louis has a piece of ribbon 48 inches in length.

Is this piece of ribbon long enough for this cake?

(3)

**(Total for Question 9 is 3 marks)**

DO NOT WRITE IN THIS AREA

DO NOT WRITE IN THIS AREA

DO NOT WRITE IN THIS AREA

DO NOT WRITE IN THIS AREA

DO NOT WRITE IN THIS AREA

DO NOT WRITE IN THIS AREA

10 The scatter diagram shows some information about 12 athletes who have run a race.

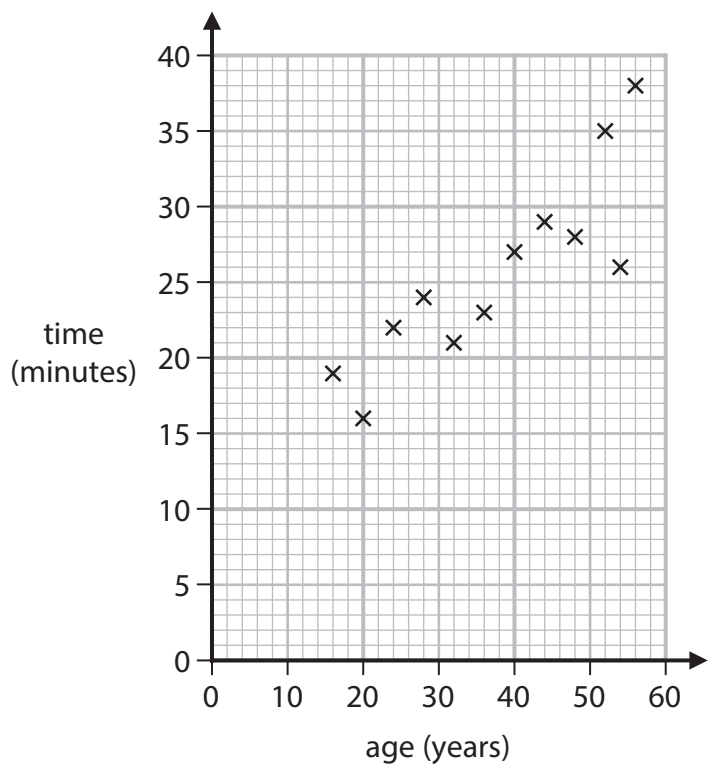

Here is the information for another athlete

- age 36, time 29 minutes.

(a) Plot this information on the scatter diagram. (1)

(b) Draw the line of best fit on the scatter diagram. (1)

(c) Describe the relationship shown in this scatter diagram. (1)

(Total for Question 10 is 3 marks)

- 11 George will cover part of a floor with tiles.  
The part of the floor is in the shape of a triangle as shown.

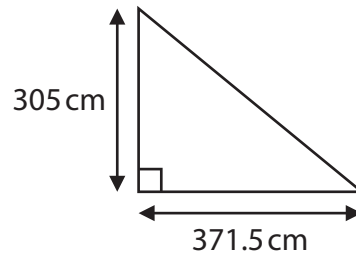

George buys tiles in packs.  
Each pack covers  $1 \text{ m}^2$  and costs £39.95

The tiles can be cut and joined.  
George gets  $\frac{1}{3}$  off the cost of the packs of tiles.

Work out the lowest cost of the tiles for George.

(5)

DO NOT WRITE IN THIS AREA

DO NOT WRITE IN THIS AREA

DO NOT WRITE IN THIS AREA

DO NOT WRITE IN THIS AREA

DO NOT WRITE IN THIS AREA

DO NOT WRITE IN THIS AREA

£

**(Total for Question 11 is 5 marks)**

12 Gabi wants to buy a flat.  
The cost of the flat is £175 000

The bank uses this formula to work out the mortgage Gabi can get.

$$M = 4.625A$$

M = mortgage (£)  
A = annual income (£)

Gabi has an annual income of £34 000  
She will have to pay a deposit for the flat.  
The deposit is the difference between the cost of the flat and the mortgage.

(a) Work out the deposit Gabi will have to pay.

(3)

£

DO NOT WRITE IN THIS AREA

DO NOT WRITE IN THIS AREA

DO NOT WRITE IN THIS AREA

Gabi invests £4000 for 3 years.  
The investment earns 2% compound interest per annum.

(b) Work out the value of the investment at the end of 3 years.

(3)

£

(Total for Question 12 is 6 marks)

**TOTAL FOR SECTION B = 48 MARKS**

**TOTAL FOR PAPER = 64 MARKS**