

Please check the examination details below before entering your candidate information

Candidate surname

Other names

**Pearson Edexcel
Functional Skills**

Centre Number

Candidate Number

**Practice exam paper for first teaching
September 2019**

Time: 1 hour 30 minutes

Paper Reference **PRACL2/01**

Mathematics

Level 2

Section B (Calculator)



You must have:

Pen, calculator, HB pencil, eraser, ruler graduated in cm and mm, protractor, pair of compasses. Tracing paper may be used.

Total Marks

My signature confirms that I will not discuss the content of the test with anyone.

Signature: _____

Instructions

- Use **black** ink or ball-point pen.
- **Fill in the boxes** at the top of this page with your name, centre number and candidate number.
- Sign the declaration.
- Answer **all** questions.
- Write your final answers in the boxes provided.
- Answer the questions in the spaces provided – *there may be more space than you need.*
- You **must** show clearly how you get your answers in the spaces provided. Marks will be awarded for your working out.
- Check your working and your answers at each stage.
- Diagrams are **not** accurately drawn, unless otherwise indicated.
- If your calculator does not have a π button take the value of π to be 3.14
- **Calculators may be used.**

Information

- The total mark for this section is 48
- The total mark for this paper is 64
- The marks for each question are shown in brackets
– *use this as a guide as to how much time to spend on each question.*
- This sign shows where marks will be awarded for showing your checks.

Advice

- Read each question carefully before you start to answer it.
- Check your answers if you have time at the end.

Turn over ►

S64039A

©2019 Pearson Education Ltd.

1/1/1/1





Pearson

SECTION B

Answer ALL questions. Write your answers in the spaces provided.

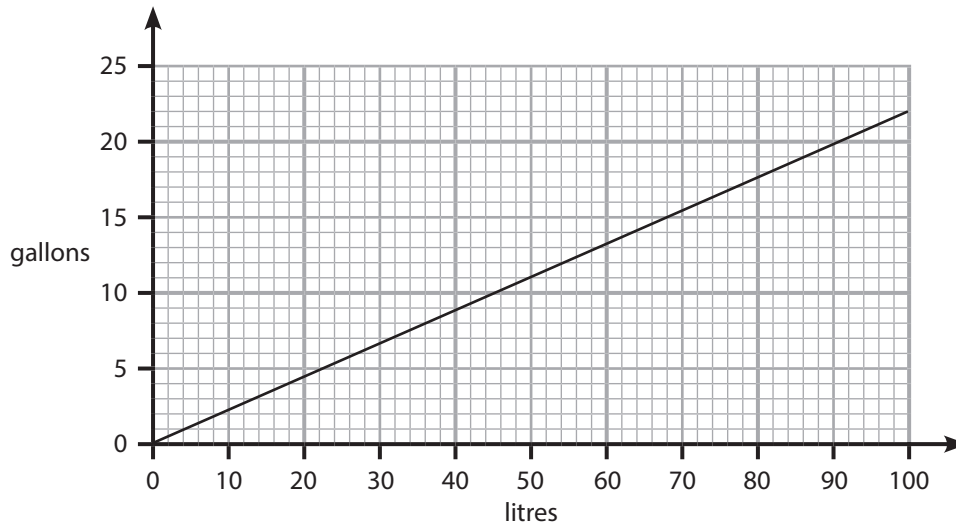
1 This graph can be used to convert between gallons and litres.



(a) Convert 60 litres to gallons.

(1)

gallons

One day

- Anaya used 44 litres of fuel
- Meera used 8 gallons of fuel.

Anaya used more fuel than Meera.

(b) Use the graph to work out how much more.
Remember to give units with your answer.

(2)

(Total for Question 1 is 3 marks)



DO NOT WRITE IN THIS AREA

DO NOT WRITE IN THIS AREA

DO NOT WRITE IN THIS AREA

DO NOT WRITE IN THIS AREA

DO NOT WRITE IN THIS AREA

DO NOT WRITE IN THIS AREA

2 David reads this advert on his county council website.

70% of the area of woodland in the county is native woodland.

This means there are 350 km² of native woodland in the county.

Work out the area of woodland in the county that is **not** native woodland.

(3)

km²

(Total for Question 2 is 3 marks)



3 The scatter diagram gives information about the temperatures at 8 different heights up a mountain.

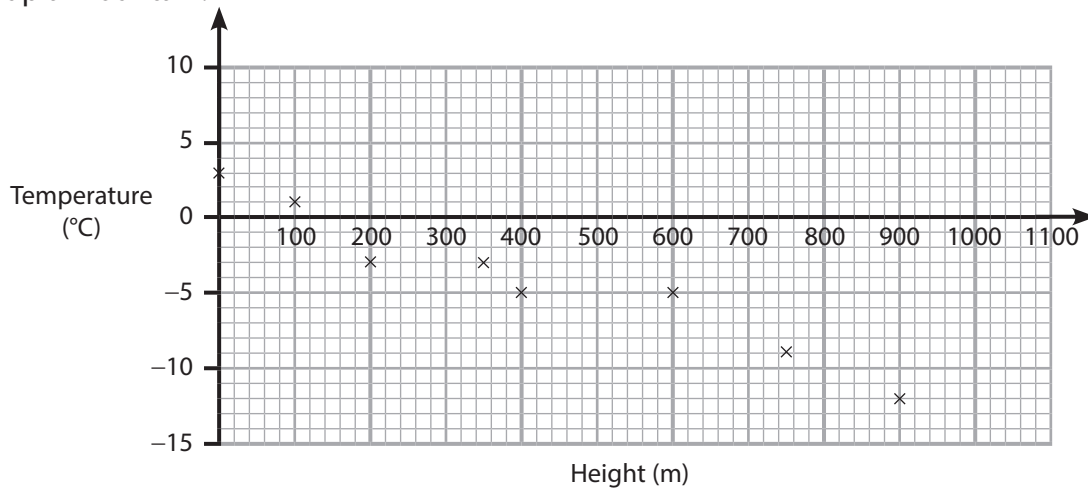

At a height of 1000 m the temperature is -13°C .

(a) Plot this information on the scatter diagram.

(1)

(b) Draw a line of best fit on the scatter diagram.

(1)

(c) Use the line of best fit to estimate the difference between the temperature at a height of 550 m and at a height of 950 m.

(2)

°C

(Total for Question 3 is 4 marks)



DO NOT WRITE IN THIS AREA

DO NOT WRITE IN THIS AREA

DO NOT WRITE IN THIS AREA

DO NOT WRITE IN THIS AREA

DO NOT WRITE IN THIS AREA

DO NOT WRITE IN THIS AREA

4 Here is a pentagon.

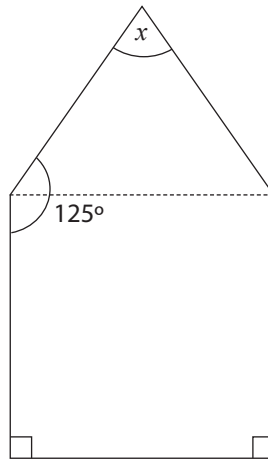

The pentagon has one line of symmetry.

Work out the size of the angle marked x .

(3)

(Total for Question 4 is 3 marks)



5 Nicola wants to put a flat roof on a bike store.

The roof will be

- made of concrete
- in the shape of a cuboid as shown.

$$\text{Density} = \frac{\text{mass}}{\text{volume}}$$

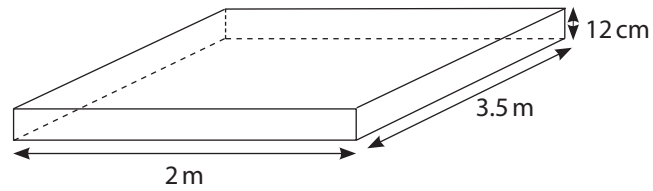

Nicola wants to put a metal strip along 2 of the longest edges of the roof.

She knows

- the density of concrete is 2300 kg per m^3
- the mass of 1 metre of metal strip is 5 kg.

Work out the total mass of the concrete and the strips she wants.

(5)

DO NOT WRITE IN THIS AREA

DO NOT WRITE IN THIS AREA

DO NOT WRITE IN THIS AREA

DO NOT WRITE IN THIS AREA

DO NOT WRITE IN THIS AREA

DO NOT WRITE IN THIS AREA



DO NOT WRITE IN THIS AREA

DO NOT WRITE IN THIS AREA

DO NOT WRITE IN THIS AREA

DO NOT WRITE IN THIS AREA

DO NOT WRITE IN THIS AREA

DO NOT WRITE IN THIS AREA

[Large empty rectangular area for writing]

kg

(Total for Question 5 is 5 marks)



6 Mai has this information about 100 flowering plants in her shop.

		Stem length	
		Short	Long
Size of flower	Small	10	18
	Large	43	29

She will take a plant at random from these plants.

(a) Work out the probability that this plant will have a large flower and a long stem.

(2)

Mai will take at random a plant from the 72 plants that have a large flower.

(b) Work out the probability that this plant will have a short stem.

(1)

(Total for Question 6 is 3 marks)

DO NOT WRITE IN THIS AREA

DO NOT WRITE IN THIS AREA

DO NOT WRITE IN THIS AREA

DO NOT WRITE IN THIS AREA

DO NOT WRITE IN THIS AREA

DO NOT WRITE IN THIS AREA



7 Sal works in a dress shop. She wants to know how well the labels on the dress hangers agree with the true size of the dresses.

The table shows information about some hangers and dresses.

		True size of dress				
		10	12	14	16	18
Label on hanger	10	8	2	1	1	–
	12	–	9	3	1	2
	14	2	1	12	–	–
	16	1	–	1	13	2
	18	1	1	2	1	13
Totals		12	13	19	16	17

Sal thinks that 2 in every 7 dresses are on hangers with the wrong label.

Is Sal correct?
Show clearly why you think this.

(4)

(Total for Question 7 is 4 marks)



- 8 James has a contract to paint 30 identical water tanks.
He has to paint the outside surfaces of each tank, but not the top.
Each surface is rectangular.

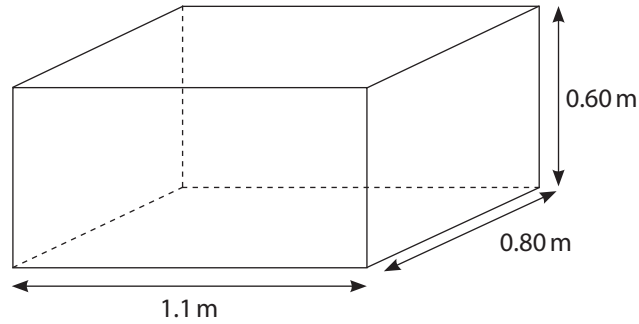

James knows that 1 tin of paint

- is enough to cover 12 m^2 of surface
- costs £26.99

Work out the total cost of the tins of paint he will need for all 30 water tanks.

(6)

DO NOT WRITE IN THIS AREA

DO NOT WRITE IN THIS AREA

DO NOT WRITE IN THIS AREA

DO NOT WRITE IN THIS AREA

DO NOT WRITE IN THIS AREA

DO NOT WRITE IN THIS AREA



DO NOT WRITE IN THIS AREA

DO NOT WRITE IN THIS AREA

DO NOT WRITE IN THIS AREA

DO NOT WRITE IN THIS AREA

DO NOT WRITE IN THIS AREA

DO NOT WRITE IN THIS AREA

£

(Total for Question 8 is 6 marks)



9 Andros has an oil fired heating system.
In a 30-day period he used a full tank of oil at a constant rate per day.

At a different time of the year the amount of oil Andros uses per day is $\frac{1}{3}$ of the rate used in the 30-day period.

(a) How many days should a full tank of oil last at this new rate?

(2)

days



(b) Use reverse calculation to show a check of your answer.

(1)

(Total for Question 9 is 3 marks)



DO NOT WRITE IN THIS AREA

DO NOT WRITE IN THIS AREA

DO NOT WRITE IN THIS AREA

DO NOT WRITE IN THIS AREA

DO NOT WRITE IN THIS AREA

DO NOT WRITE IN THIS AREA

10 Lena recorded the number of late trains at a station in a day over a period of time.

She shows this information in a diagram.

Number of days	5									
	4		*							
	3		*	*						
	2	*	*	*	*	*				
	1	*	*	*	*	*	*			*
		1	2	3	4	5	6	7	8	9
		Number of late trains in a day								

Key:

*
*
4

means there were 2 days when 4 trains were late each day.

(a) For this information work out the median number of late trains in a day.

(2)

Lena says 'The median number of late trains in a day, from this information, is a good estimate of the average number of trains late over the period of time.'

(b) Is Lena correct?
Explain why you think this.

(1)

(Total for Question 10 is 3 marks)



- 11 Joanna is a landscape gardener.
She has to fill a circular space with flowers.

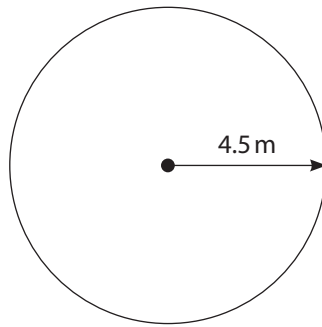

The radius of the circular space is 4.5 metres.

Joanna will plant 40 flowers per square metre of space.

She will plant 4 times as many red flowers as white flowers.

How many red flowers will she plant?

(5)

DO NOT WRITE IN THIS AREA

DO NOT WRITE IN THIS AREA

DO NOT WRITE IN THIS AREA

DO NOT WRITE IN THIS AREA

DO NOT WRITE IN THIS AREA

DO NOT WRITE IN THIS AREA



DO NOT WRITE IN THIS AREA

DO NOT WRITE IN THIS AREA

DO NOT WRITE IN THIS AREA

DO NOT WRITE IN THIS AREA

DO NOT WRITE IN THIS AREA

DO NOT WRITE IN THIS AREA

[Large empty rectangular area for writing]

[Small empty rectangular box]

(Total for Question 11 is 5 marks)



12 Jim owns a small business.

The table shows information about the weekly wage of the 40 workers.

Weekly wage (£)	Number of workers
320	10
370	13
420	8
470	7
520	2

Jim wants to increase the mean wage by 4%, plus £10

Jim thinks the new mean weekly wage of these workers will be more than £415

Is Jim correct?
You **must** show your working.

(6)

DO NOT WRITE IN THIS AREA

DO NOT WRITE IN THIS AREA

DO NOT WRITE IN THIS AREA

DO NOT WRITE IN THIS AREA

DO NOT WRITE IN THIS AREA

DO NOT WRITE IN THIS AREA



DO NOT WRITE IN THIS AREA

DO NOT WRITE IN THIS AREA

DO NOT WRITE IN THIS AREA

DO NOT WRITE IN THIS AREA

DO NOT WRITE IN THIS AREA

DO NOT WRITE IN THIS AREA

Blank area for student response.

(Total for Question 12 is 6 marks)

TOTAL FOR SECTION B = 48 MARKS
TOTAL FOR PAPER = 64 MARKS





DO NOT WRITE IN THIS AREA

DO NOT WRITE IN THIS AREA

DO NOT WRITE IN THIS AREA

DO NOT WRITE IN THIS AREA

DO NOT WRITE IN THIS AREA

DO NOT WRITE IN THIS AREA

BLANK PAGE



DO NOT WRITE IN THIS AREA

DO NOT WRITE IN THIS AREA

DO NOT WRITE IN THIS AREA

DO NOT WRITE IN THIS AREA

DO NOT WRITE IN THIS AREA

DO NOT WRITE IN THIS AREA

BLANK PAGE



S 6 4 0 3 9 A 0 1 9 2 0



DO NOT WRITE IN THIS AREA

DO NOT WRITE IN THIS AREA

DO NOT WRITE IN THIS AREA

DO NOT WRITE IN THIS AREA

DO NOT WRITE IN THIS AREA

DO NOT WRITE IN THIS AREA

BLANK PAGE

